

軒先部 縮尺 1 : 5

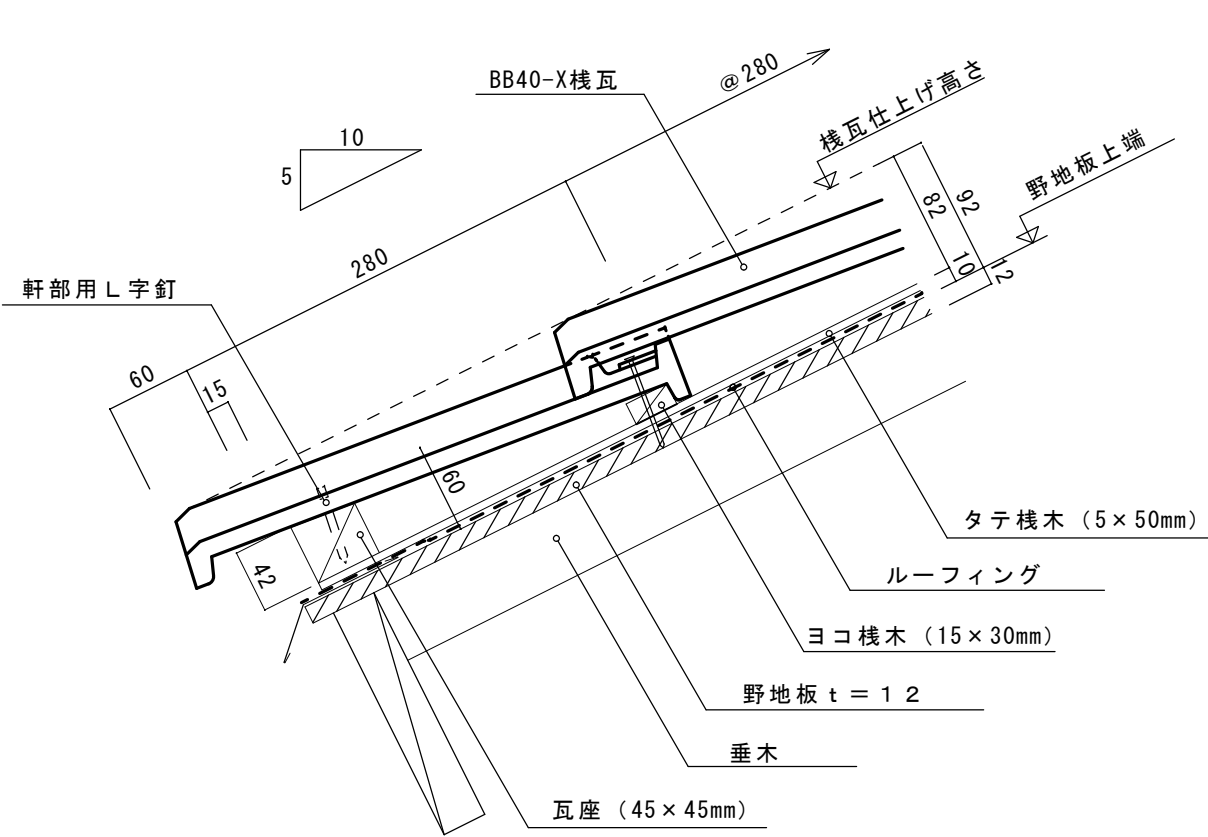

大棟部 縮尺 1 : 5

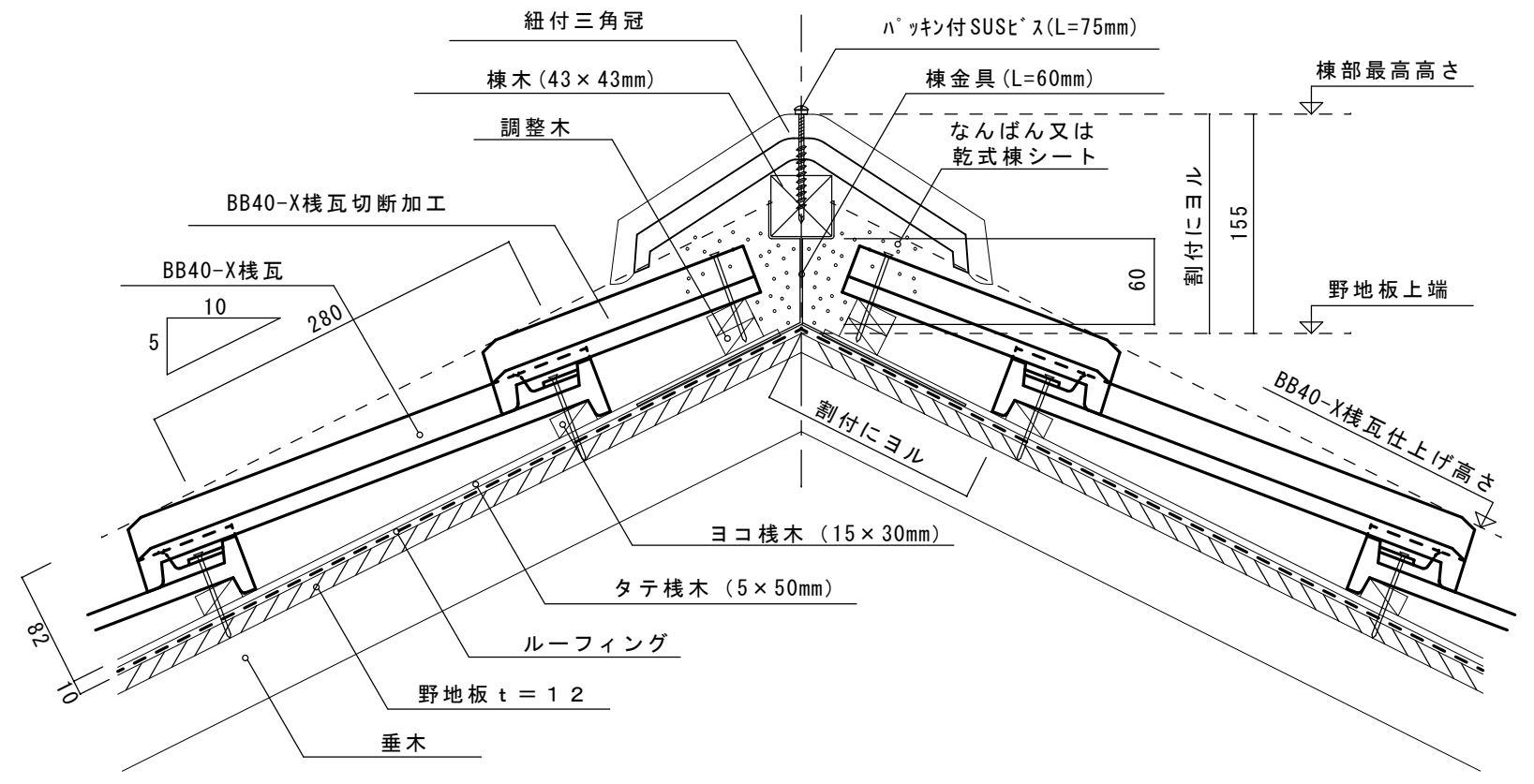

袖部横断面 縮尺 1 : 5

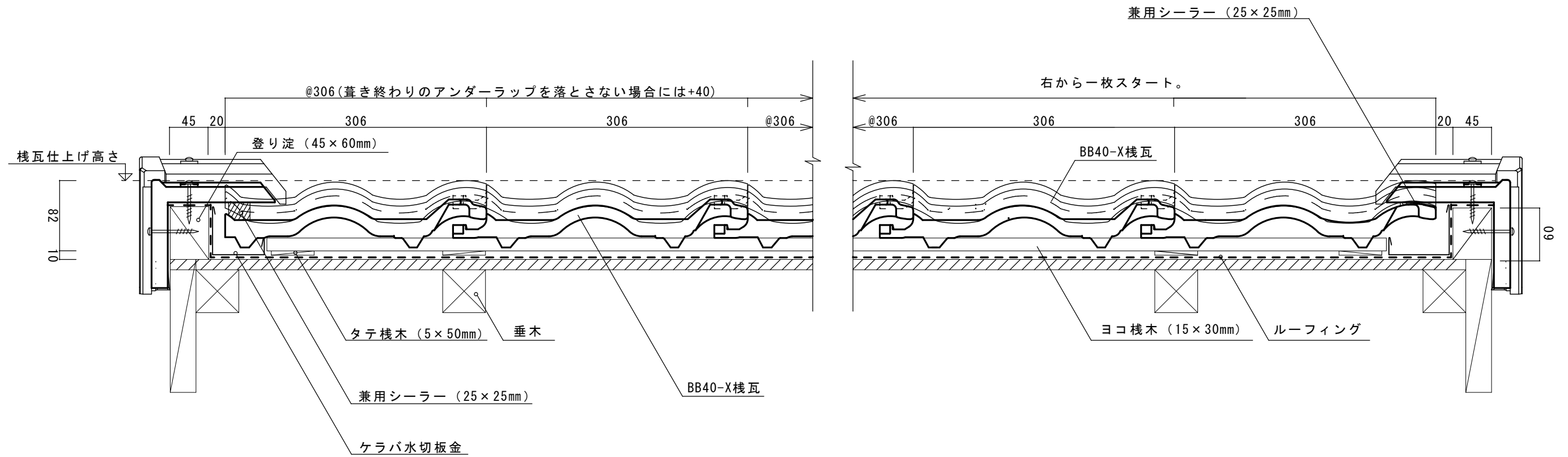

図面名称

BB40-X 軒先・袖部・棟部詳細図

審査

設計

制作日

17.09.01

縮尺

1:5

図面No.

001

隅棟部 縮尺 1 : 5

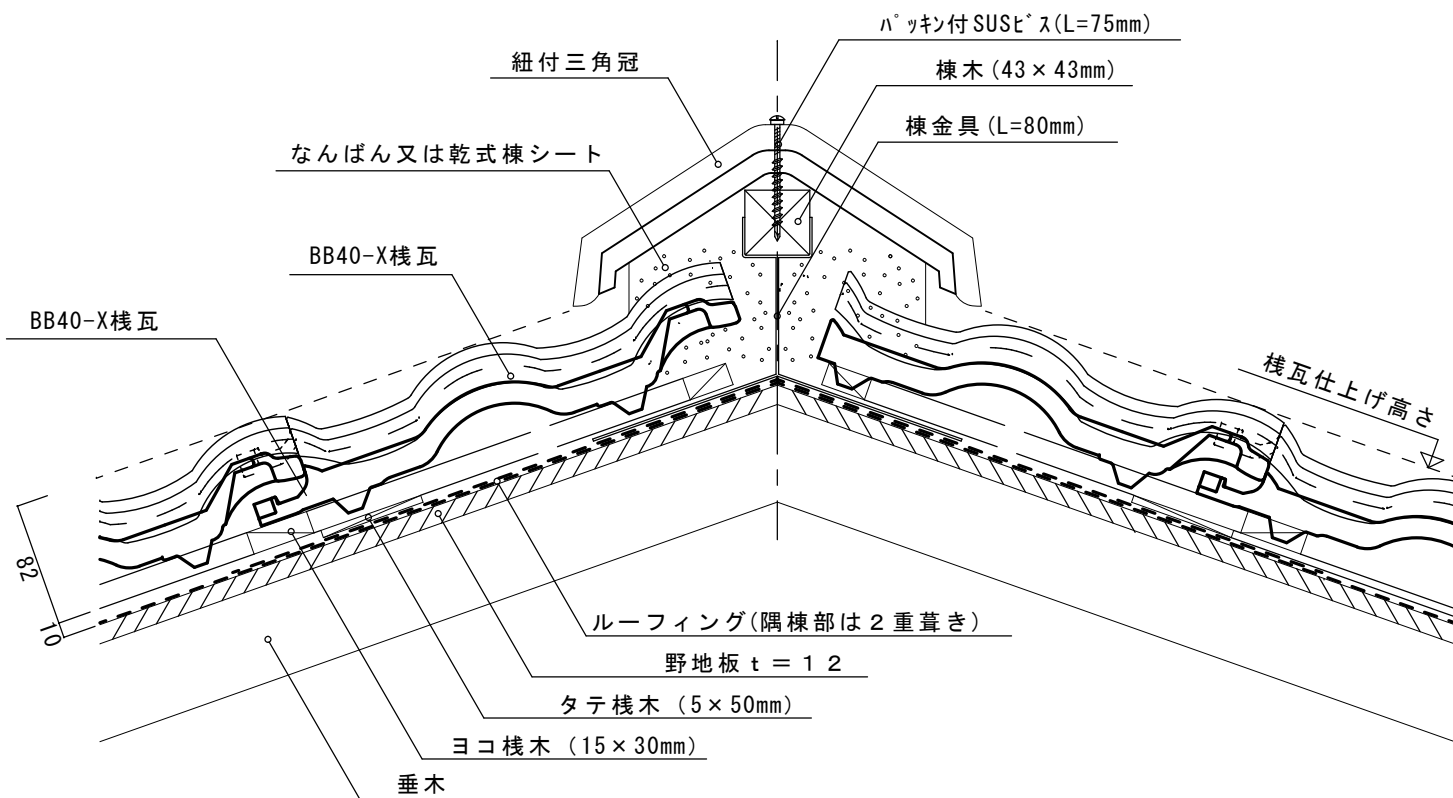

平行壁部 縮尺 1 : 5

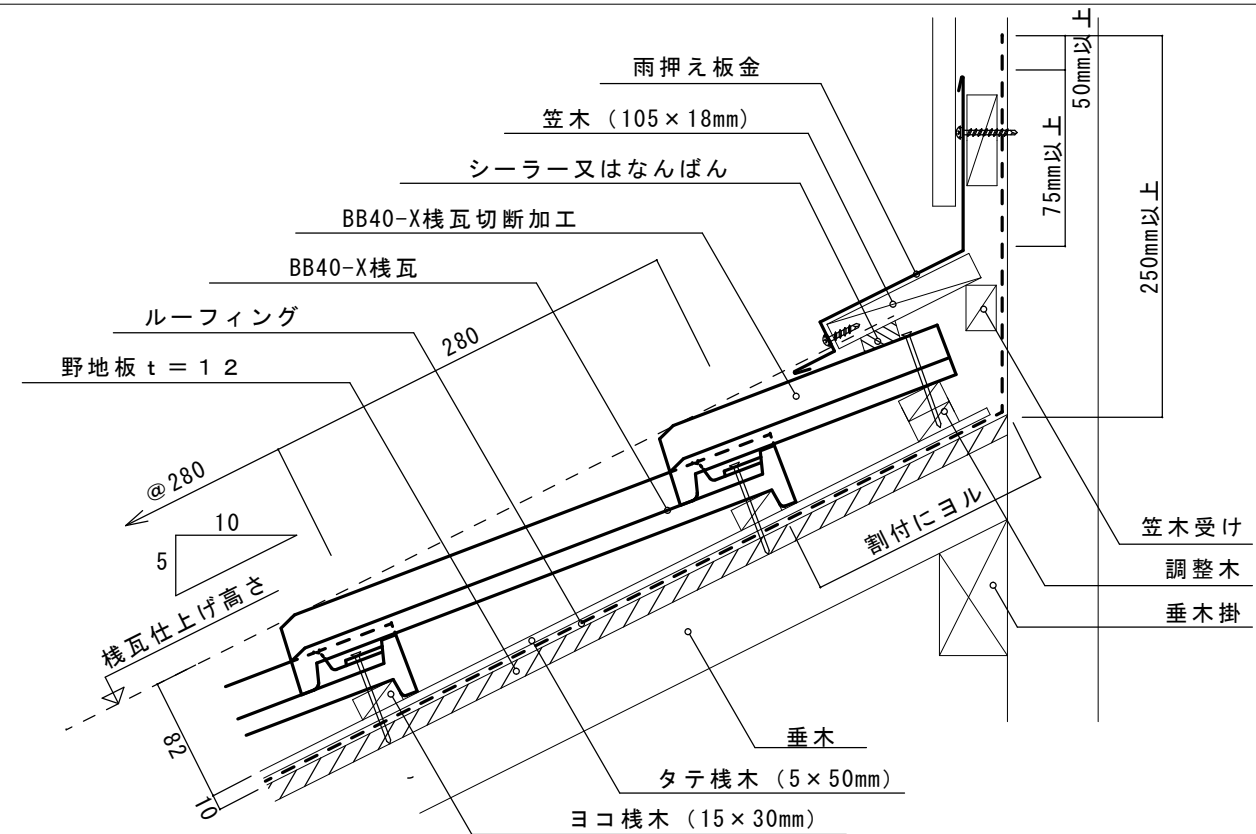

谷部 縮尺 1 : 5

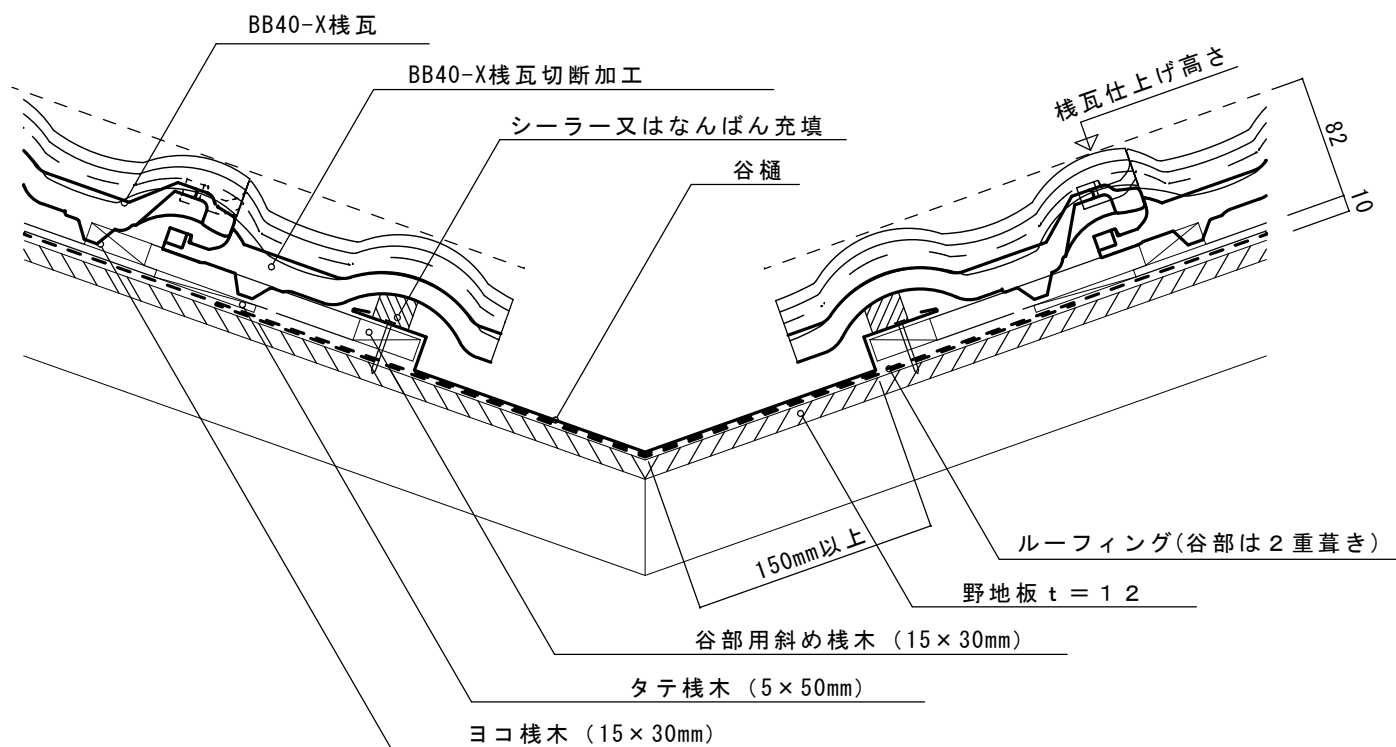

流れ壁部 縮尺 1 : 5

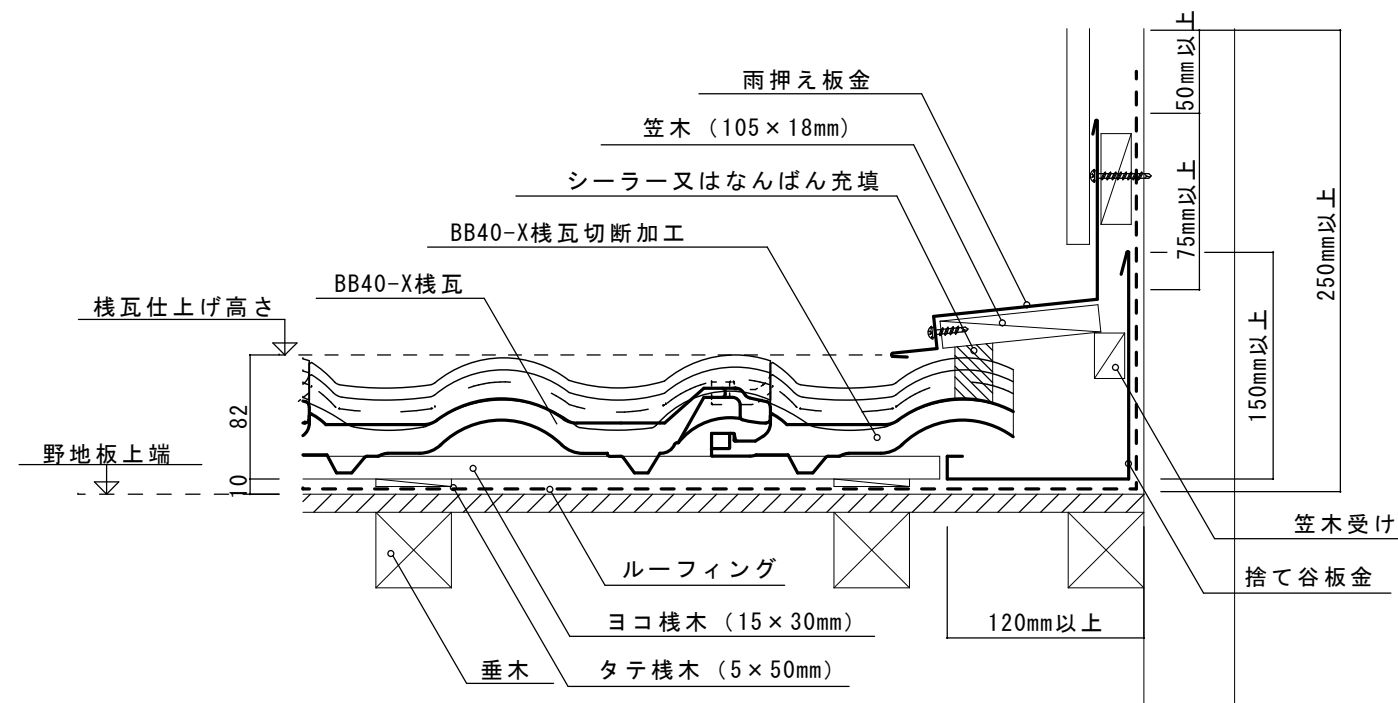

図面名称	審査	設計	制作日	縮尺	図面No.
BB40-X 平行壁・流れ壁部詳細図 隅棟・谷部詳細図			17.09.01	1:5	002